

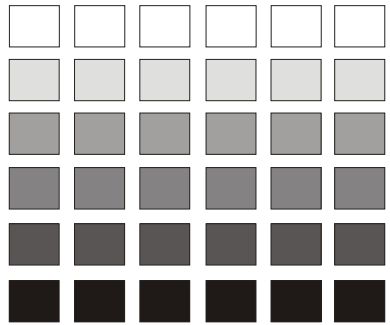

Supports DBS 576 Version 5.1

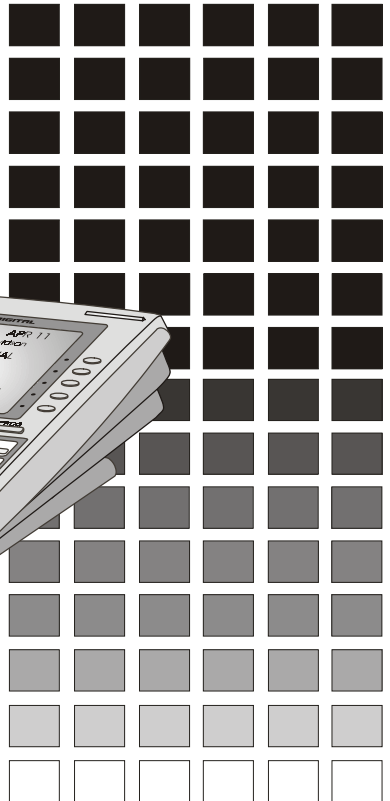

Section 521 Built-In ACD Supervisor Guide



DBS 576 Version 5.1
issued April 2002
(ACD Version 5.2)



Warning: The service information is designed for experienced repair technicians only and is not designed for use by the general public. It does not contain warnings or cautions to advise non-technical individuals of potential dangers in attempting to service a product. Products powered by electricity should be serviced or repaired only by experienced professional technicians. Any attempt to service or repair the product or products dealt with in this service information by anyone else could result in serious injury or death.

FCC Warning

This equipment generates, uses, and can radiate radio frequency energy, and, if not installed and used in accordance with the instruction manual, may cause interference to radio communications. This equipment has been tested and found to comply with the limits for a Class A digital device pursuant to Part 15 of FCC Rules, which are designed to provide reasonable protection against such interference when operated in a commercial environment. Operation of this equipment in a residential area is likely to cause interference, in which case the user at his own expense will be required to take necessary measures to correct the interference.



CAUTION: When using the ACD “Silent Monitor” feature in some states it is illegal (or civilly actionable) to monitor telephone communications without giving prior warning to all participants. These laws do not make the Silent Monitor feature on the telephone system illegal. Before activating this feature, please check applicable state and federal laws.

The contents of this document are subject to change without notice and do not constitute a commitment on the part of Panasonic Telecommunication Systems Company (PTSC). Every effort has been made to ensure the accuracy of this document. However, due to ongoing product improvements and revisions, Panasonic cannot guarantee the accuracy of printed material after the date of publication nor can it accept responsibility for errors or omissions. Panasonic will update and revise this document as needed.

The software and hardware described in this document may be used or copied only in accordance with the terms of the license pertaining to said software or hardware.

©Copyright 2002 by Panasonic Telecommunication Systems Company (PTSC)

All rights reserved.

Contents

General System Information	1
Configuration	1
Specifications	2
Basic Service Flow	4
ACD Call Handling Program	5
Selecting Program Processing	5
Programming by Commands	7
Transfer Destination Voice Number	13
Silent Monitor	14
<hr/>	
Supervisor Features	16
Common Operation of Supervisor Menu	16
Activating Supervisor Menu	16
Displaying System Information	17
Common Operation for Supervisor Customization	18
Supervisor Customization	18
Direct Incoming Call Setting	19
Transferring Incoming Call Setting	21
Changing Supervisor IDs and User Information Recording ID	23
Registering Agent IDs	24
Confirming Agent IDs	26
Setting on Service Flow Details	27
Supervisor Monitoring	28
Traffic Information	29
Waiting Call	30
Agent Status	31

MIS Report Features	32
MIS Report Outline	32
MIS Report Operation	35
User Information Recording	45

Agent Features	47
Log-in / Log-out	47
Available/Unavailable	48
Log Out Confirmation Feature	48
Work Unit Count	49
Zip Tone	50
Key Assignment	50

Index	Index-1
--------------------	---------

General System Information

Configuration

The Built-In ACD System is a simple ACD system that installed in the DBS 576 System. The built-In ACD system is composed of the two circuit cards; the ACD card and the VPU/4 card.

The system configuration is shown below. Using RS-232C port allows MIS (Management Information System) reports to be output to a printer or PC but not to the both simultaneously.

The DBS 576 System configured for a maximum of 576 ports can support a maximum of two Built-In ACD systems. Note that a single-shelf (96-port) configuration can accommodate only one ACD system.

Figure 1. ACD Configuration

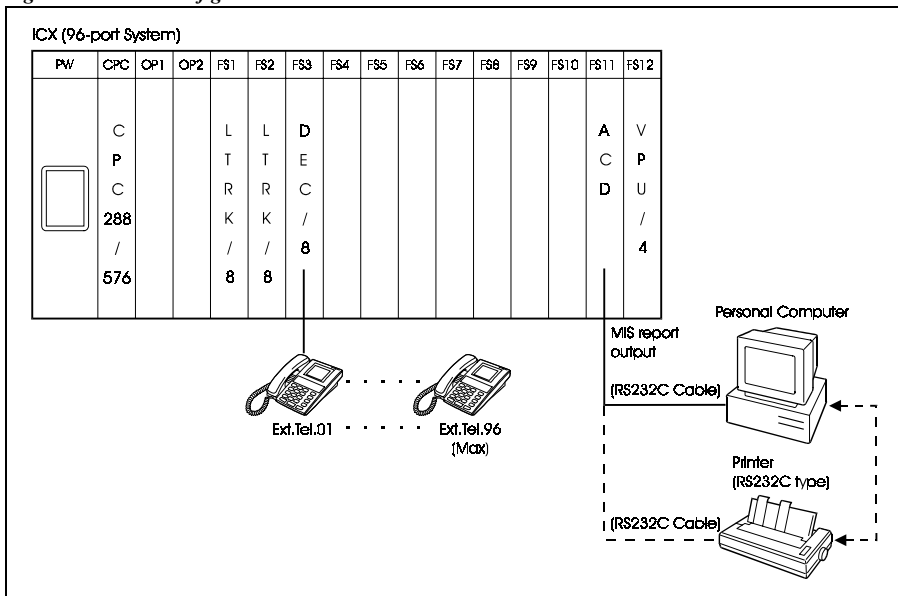

Note: Standard RS232C cables cannot be used for connection. Use the special cable included with the ACD card. For PC/printer connecting conditions, see the ACD installation section.

Specifications

The following tables show the major specifications of the Panasonic Built-In ACD system (maximum):

Table 1. Maximums per ACD System: ACD Versions 2.0 to 4.0

Item	ACD Version 2.0	ACD Version 3.0	ACD Version 4.0
Agent Group	2	3	3
Agent IDs/system	64	64	64
Number of Agents/system	32	32	32
Supervisor IDs/system	2	6	6
Voice port/system	4 ports are shared.	4 ports are shared	4 ports are shared
Music Port	1 Music on Hold source on the CPC is used.	1 Music on Hold source on the CPC is used.	Multiple music/message choices are available by using a RAD (recorded announcement device) .
MIS Monitor Port	1 (RS232C, 9600bps)	1 (RS232C, 9600bps)	1 (RS232C, 9600bps)
Number of user guidance messages	6 (Max. 16 seconds/message)/system	6 (Length of each message can vary, with 96 seconds total recording time available.)	6 (Length of each message can vary, with a total of 96 seconds recording time available.)
MIS Reports	Max, 2-week memory	Max, 2-week memory (updated on Mondays)	Max, 2-week memory (updated on Mondays)
Maximum Calls Queued	50	50	50

Table 2. Maximums per ACD System: ACD Versions 5.1 to 5.2

Item	ACD Version 5.1	ACD Version 5.2
Agent Group	3	3
Agent IDs/ system	64	64
Number of Agents/system	32	32
Supervisor IDs/ system	6	6
Voice port/ system	4 ports are shared	4 ports are shared
Music Port	Multiple music/message choices are available by using a RAD (recorded announcement device) .	Multiple music/message choices are available by using a RAD (recorded announcement device) .
MIS Monitor Port	1 (RS232C, 9600bps)	1 (RS232C, 9600bps)
Number of user guidance messages	6 (Length of each message can vary, with a total of 96 seconds recording time available.)	6 (Length of each message can vary, with a total of 96 seconds recording time available.)
MIS Reports	Two MIS options: existing MIS and new advanced MIS with support for multiple supervisors and ability to use call status information	Two MIS options: existing MIS and new advanced MIS with support for multiple supervisors and ability to use call status information
Maximum Calls Queued	50	50
Agent Features	6 (Log-in/Log-out, Available/Unavailable, Work Unit Count, Wrap Feature, Zip Tone, and Key Assignment)	7 (Log-in/Log-out, Available/Unavailable, Work Unit Count, Wrap Feature, Zip Tone, Key Assignment, and (new) Log Out Confirmation)
ACD Call Handling Program - Play parameters	2 (Guidance Number Setting and Message Play)	3 (Guidance Number Setting, Message Play, and (new) Break Out)

Basic Service Flow

The following chart shows the basic flow of ACD services.

Commands can be used to set any call distribution operation in the ACD Call Handling Program.

At initial start-up of ACD, programming is performed automatically using default sample programs.

Figure 2.

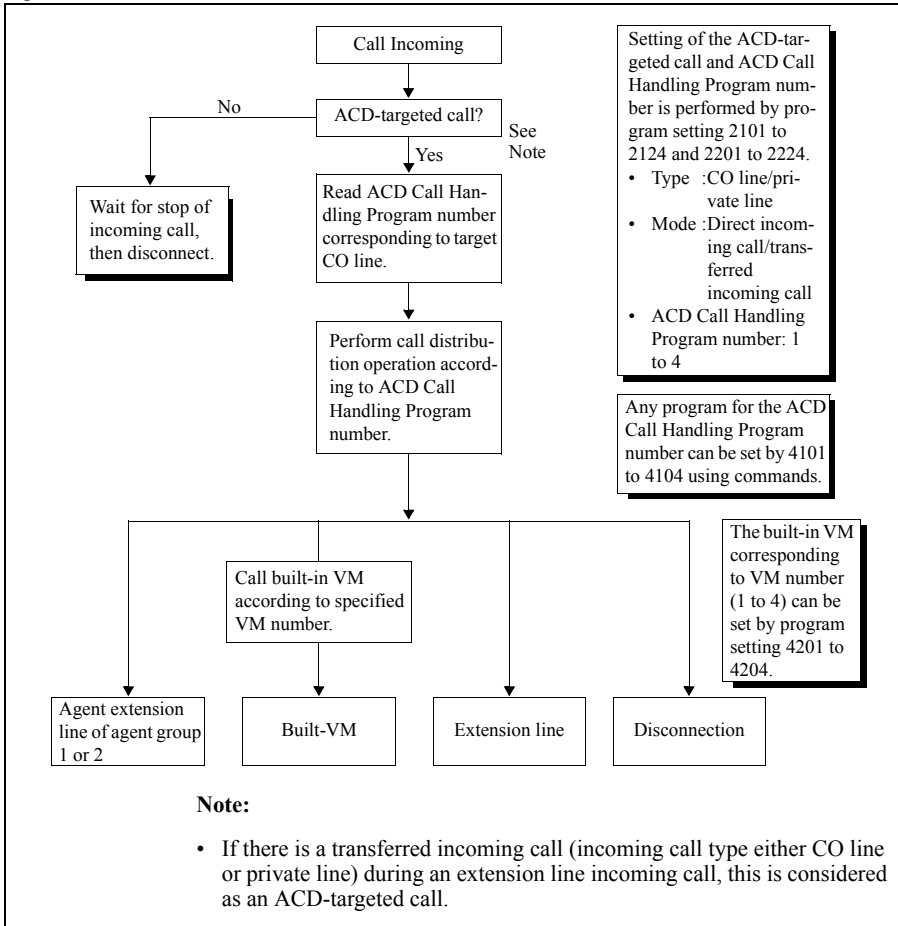

ACD Call Handling Program

Commands can be used to set any call distribution operation for each of the ACD Call Handling Program numbers (4101 to 4104).

For details on the content of default sample programs, see "Chapter 2. Programming, ACD Call Handling Program Setting."

Selecting Program Processing

You can select program processing by the FF key. The following shows the procedure and flow of operations from entry of program numbers to selection of program processing.

Operation

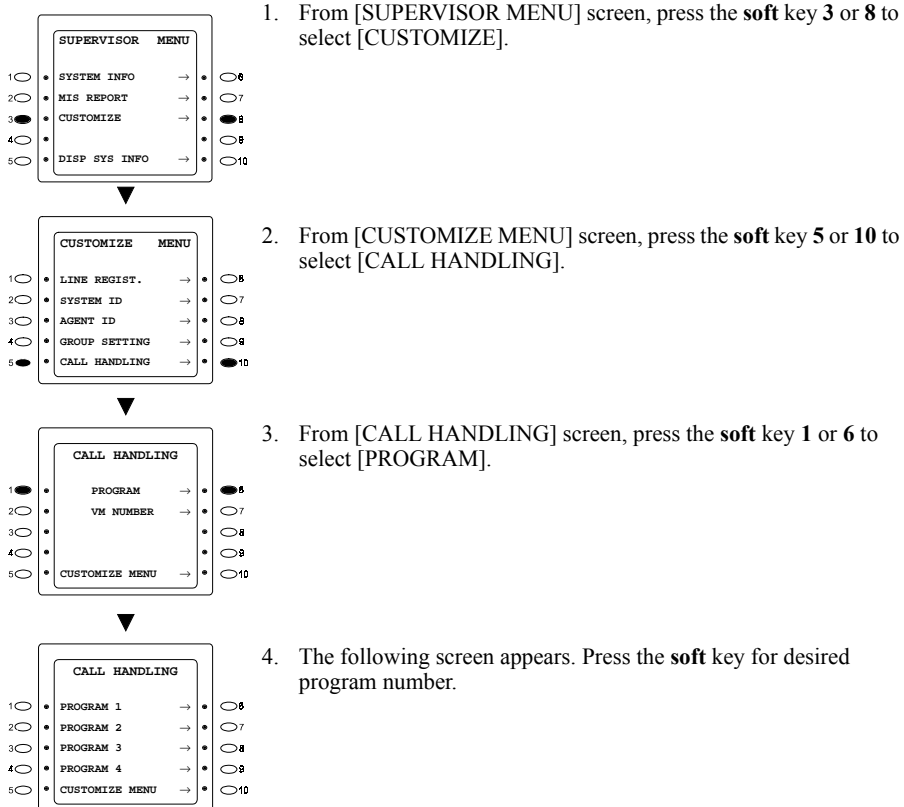

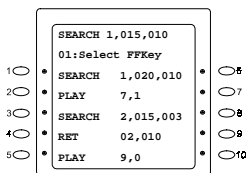

- The List Mode screen is displayed. This screen displays the current setup status. The program lines currently displayed at 1st LCD are the target of processing. The **NEXT** or **HOLD** keys move to the next line. The **PREV** or **FLASH** keys return to the previous line.

- Press the **FF** key to determine processing on the currently displayed program line on the 1st LCD.

FF1 : EDIT
 FF2 : INSERT
 FF3 : DELETE
 FF6 : ALL DELETE

The following items describe the details of subsequent processing.

Note:

- Pressing the **PROG** key returns to the ACD Call Handling Program number in step 1.

Figure 3.

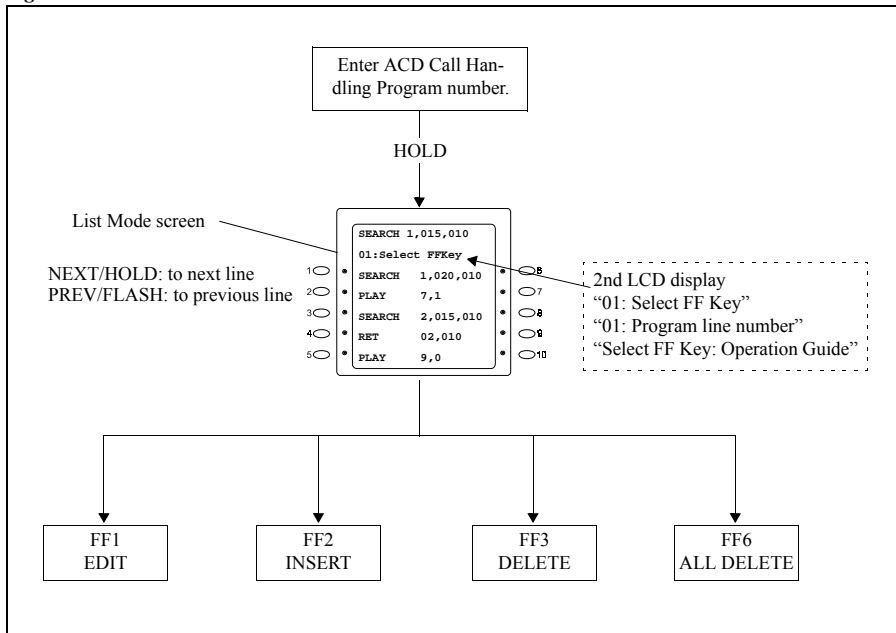

Programming by Commands

After you have determined the desired process by the FF key, you can customize any program using the six available commands.

The following table shows a list of commands that are used:

Table 3.

No	Command	Parameter1	Parameter2	Parameter3	Description
1	END/DISK				End/Disconnect <ul style="list-style-type: none"> • Ends the ACD Call Handling Program at this line. • When there is a call agent, ends by on-hook disconnection of the agent that replied to the call.
2	FWD	Transfer Destination Extension Line Number Setting 0 to 9999 (max. 4 digits) (must be set)	No Answer Timer 001 to 600 (seconds) (infinite when not set)		Forward EXT <ul style="list-style-type: none"> • Performs an extension line tone call to the transfer destination extension line specified in parameter 1, and performs a transfer after responding to the other party. • When there is no response, the response from the other party is waited for until the end of the no answer timer set in parameter 2.
3	FWDVM	Transfer Destination VM Number Setting 1 to 4 (must be set)	No Answer Timer 001 to 600 (seconds) (infinite when not set)		Forward VM <ul style="list-style-type: none"> • Setting of the built-in VM corresponding to the transfer destination VM number of parameter 1 is set by programming setting 4201 to 4204. • Performs an extension line tone call to the transfer destination built-in VM specified in parameter 1, and performs a transfer after the VM response. • When there is no response, the response from the other party is waited for until the end of the no answer timer set in parameter 2.
4	PLAY	Guidance Number Setting	Message Play Option <ul style="list-style-type: none"> • 0: Play • 1: Play and Search 	Break Out Feature <ul style="list-style-type: none"> • 0: Disable • 1: Enable 	Answer & Play Message <ul style="list-style-type: none"> • Plays back specified guidance in response to a call. • Guidance numbers 1 to 6 are for user recording. • Guidance numbers 7 to 9 are for fixed recording messages. (i.e., 7 = “wait for available agent” message, 8 = “transfer” message, and 9 = “disconnect” message.) • Allows callers to press a key while the guidance message is playing to go to the operator, an extension number, or a voice mail box, if the Break Out feature is enabled in parameter 3.

No	Command	Parameter1	Parameter2	Parameter3	Description
5	SEARCH	Agent Group Setting (must be set)	Search Time Setting 001 to 600 (seconds) (must be set)	No Answer Timer 001 to 600 (seconds) (infinite when not set)	Agent Search <ul style="list-style-type: none"> Performs a transfer to transferable agents within the agent group specified in parameter 1. When there is no transferable agent, performs a search until end of the search time set in parameter 2. When the transferred agent does not respond, a response from the other party is waited for until the end of the no answer timer set in parameter 3, and transfer to another Agent is moved to after the end of the no answer timer.
6	RET	Program Line Number Setting 1 to 20 (max. 20 lines) (must be set)	Count Setting 1 to 255 (times) (must be set)		Return <ul style="list-style-type: none"> Repeats the program from the line number specified in parameter 1 up to this line for the count specified in parameter 2.
7	RAD	Port #			Recorded Announcement Device <ul style="list-style-type: none"> The caller hears MOH if the RAD port # is invalid or incorrect. THE DBS 576 Built-in ACD must use different RAD ports than Easy Run Courier ACD. RAD equipment will connect to AEC ports. No start or stop control method will be provided to control the RAD equipment. RAD equipment must be capable of operating in the continuous play mode. Up to 8 RAD devices can be connected to AEC's per system. This command must be followed by a SEARCH, FWD or FWDVM command. For programming (<i>See Section 400 Programming Manual on page 1-168.</i>)
8	NOP				No Operation of Break Out feature <ul style="list-style-type: none"> If the caller presses the key for the Break Out Line corresponding to this command, the guidance message continues to play.
9	BOEND				Break Out End <ul style="list-style-type: none"> Terminates the Break Out feature.

Operation

The following describes operation in each of the processes.

EDIT (FF1)

This command resets the current setting of displayed program lines. Edit is repeated from the specified program line through to the currently registered final program line (excluding the END/DISC line).

The following screen display shows an example of selection and setting of the SEARCH command.



1. Press **soft** keys **1**, **2** or **3** or **6**, **7** or **8** for the command to be set, and press the **HOLD** key.
Example: Press **soft** key **3** to select SEARCH.

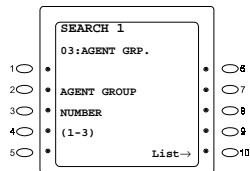

2. Set parameter 1, and press the **HOLD** key.
Example: Press key **2** to set group 2.

Example:

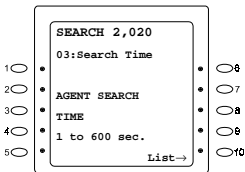

3. Set parameter 2, and press the **HOLD** key.
Example: Press keys **0**, **1** and **5** to set the Search Timer to 15.

Example:

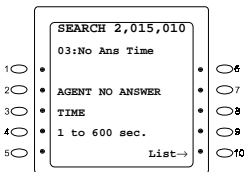

4. Set parameter 3, and press the **HOLD** key.
Example: Enter three digits to set the No Ans Timer.

The program line that was set is updated when the final parameter is set. The next line is moved to, and the screen in step 1 is redisplayed.



- Repeat steps 1 to 4 to set other program lines, and end programming at the END/DISC line.

Note:

- The program line is updated when the final parameter setup is completed at each command, and the next line is moved to. (Example: In the case of the FWD command, the program line is updated when the no answer timer of parameter 2 is input, and the next line is moved to.)
- If you press **soft** key **10** and select List at any of the above steps, the List Mode screen is redisplayed.
- The END/DISC line cannot be changed nor deleted.

INSERT (FF2)

This command inserts a new line in the current setting of displayed program lines. Insertion can be repeated up to 19 lines.

The following screen display shows an example of insertion and setting of the SEARCH command.



- Press the **soft** key **1, 2 or 3** or **6, 7 or 8** for the commands to be set, and press the **HOLD** key.

Example: Press **soft** key **3** to select SEARCH.

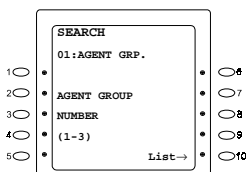

- Set parameter 1, and press the **HOLD** key.
- Example: Press key **1** to set group 1.

Example:



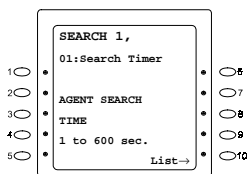

3. Set parameter 2, and press the **HOLD** key.
Example: Press the **0**, **1** and **0** keys to set the Search Timer to 10 seconds.

Example:

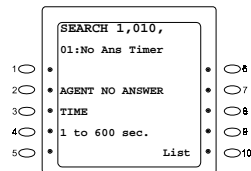

4. Set parameter 3, and press the **HOLD** key.
Example: Enter three digits to set the No Ans Timer.

The program line that was set is updated when the final parameter is set. The next line is moved to, and the screen in step 1 is redisplayed.

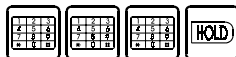

5. Repeat steps 1 to 4 to set insertion of other program lines, and end programming at the END/DISC line.

Note:

- If you press **soft key 10** and select List at any of the above steps, the List Mode screen is redisplayed.
- The END/DISC line cannot be changed nor deleted.

DELETE (FF3)

This command deletes the current setting of displayed program lines. Deletion can be repeated up to 19 lines.

The following screen display shows an example of deletion of line 01.

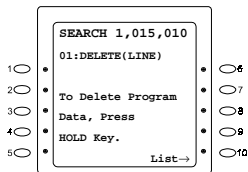

1. Confirm the specified line to be deleted, and press the **HOLD** key.
Example: Line 01 is deleted.



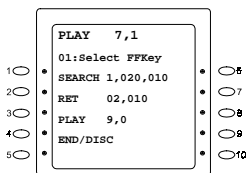

2. The program line that was displayed is deleted, and the List Mode screen is redisplayed. When the specified line is deleted, each subsequent program line is shifted up.

Note: If you press soft key 10 and select List at any of the above steps, the List Mode screen is redisplayed.

ALL DELETE (FF6)

This command deletes all settings currently set to all lines in the currently displayed program.

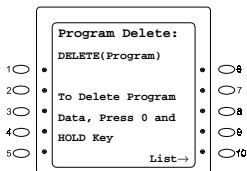

1. Press key 0, and the **HOLD** key.



2. All of the program that was displayed is deleted, and only the default END/DISK line is displayed.

Note: If you press **soft key 10** and select List at any of the above steps, the List Mode screen is redisplayed.

Transfer Destination Voice Number

Outline

Sets the voice mail extension line number and access code corresponding to the transfer destination voice mail number (1 to 4).

Operation

1. From [SUPERVISOR MENU] screen, press the **soft** key **3** or **8** to select [CUSTOMIZE].

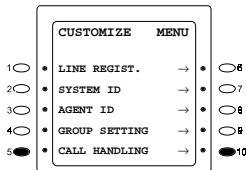

2. From [CUSTOMIZE MENU] screen, press the **soft** key **5** or **10** to select [CALL HANDLING].

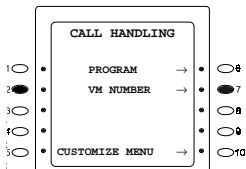

3. From [CALL HANDLING] screen, press the **soft** key **2** or **7** to select [VM NUMBER].

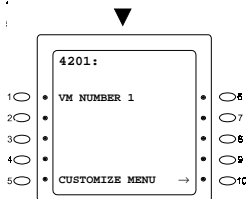

4. The 4201 setting screen appears. Enter the extension number + access code (max, 16 digits) using the 10-key pad, and press **HOLD** key to make setting. Each time the **HOLD** key is pressed, the setting changes: 4201→4202→4203→4204.



5. To return to [CUSTOMIZE MENU] screen, press the **soft** key **5** or **10**.

Silent Monitor

Version 3.0 and higher



CAUTION: When using the ACD “Silent Monitor” feature in some states it is illegal (or civilly actionable) to monitor telephone communications without giving prior warning to all participants. These laws do not make the Silent Monitor feature on the telephone system illegal. Before activating this feature, please check applicable state and federal laws.

The Silent Monitor feature allows an ACD supervisor to monitor a call between an ACD agent and a caller without the knowledge of either party. (See *CAUTION*, above.) If necessary, the ACD supervisor can initiate a three-way call by barging into the call.

Operation

To initiate Silent Monitor:

Table 4. Initiating Silent Monitor

Action	Result
Press ON/OFF + 768 + Extension number you want to monitor OR...	The Silent Monitor feature is active, and the extension is being monitored. (The Silent Monitor key flashes green when Silent Monitor is active.)
Press the FF key assigned as a Silent Monitor Key + Extension number you want to monitor* OR...	
Press only the Silent Monitor Key if the FF key has been preprogrammed to monitor a specific extension number. You do not need to enter the extension number.	

Notes:

- The Silent Monitor key is disabled when the extension assigned to that key is idle, dialing or ringing.
- If the Supervisor retrieves a call while monitoring a extension, he or she can suspend the monitoring by pressing the ON/OFF key.
- Press the CONF key during the monitoring to initiate a three-way call.

Silent Monitor Color Definitions

Table 5. Silent Monitor Color Definitions

FF Key Color	Definition	Possible Operation
Clear	Cannot Monitor	None
Solid Red	Able to monitor	Press Silent Monitor key
Flashing Green	Not monitoring	On-Hook or CONF

Notice

- Be sure all phone that should NOT be allowed to monitor have a COS that restricts monitoring. For programming COS (*See Section 400 Programming manual on page 1-50.*)
- Silent Monitor is allowed or denied by setting the appropriate extension COS.
- Only one supervisor can initiate Silent Monitor on an individual extension at any given time.
- Display telephones can initiate Silent Monitoring. SLTs cannot initiate Silent Monitoring.
- Display telephones and SLTs can be monitored.
- A supervisor cannot initiate Silent Monitoring on an extension when the extension is on a conference call.

Supervisor Features

Supervisor features are roughly divided into three groups:

- 1) Supervisor customization: Set for requested features of ACD.
- 2) Supervisor monitoring: Monitors ACD system status on a large LCD telephone.
- 3) MIS report feature: Outputs agent management information.

All of the above features are included in the supervisor menu. The following describes each of the features and the common operations.

Common Operation of Supervisor Menu

Read this section first before using the supervisor features.

Activating Supervisor Menu

Operation

From Large Display Telephone

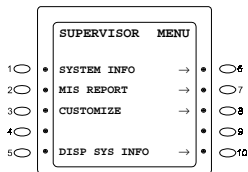

1. Press the Log-in button (**FF** key).
2. Enter the 4-digit supervisor ID. If a supervisor ID is not entered, you cannot enter supervisor menu. Make sure to assign supervisor ID at installation. (Default: [No assignment])
3. Select a desired menu by using the **soft** keys from the above screen.
4. For further operations, see desired section in this manual.

Displaying System Information

Operation

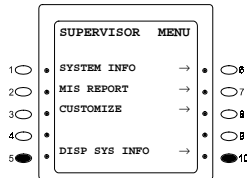

- From [SUPERVISOR MENU] screen, press the **soft** key **5** or **10** to select [DISP SYS INFO].



- When the following screen appears, press the ON/OFF button or hang up the telephone.

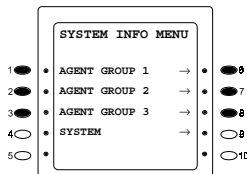

- Group 1 monitoring: Press the **soft** key **1** or **6** to select Agent Group 1.
Group 2 monitoring: Press the **soft** key **2** or **7** to select Agent Group 2.
Group 3 monitoring: Press the **soft** key **3** or **8** to select Agent Group 3.

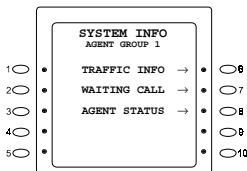

- After selecting one of the above groups, the following menu selection screen appears. Use **soft** keys to select a desired item. This figure shows the case where [AGENT GROUP 1] is selected.
- For further operations, see desired section of this manual.

Note: The [DISP SYS INFO] screen allows you to continue placing and receiving telephone calls. This function is not available with other commands.

Common Operation for Supervisor Customization

- 1) PROG KEY : Returns to Supervisor Top Menu.
- 2) AUTO KEY : Goes to the upper layer.
- 3) HOLD KEY : Validates data or goes to the next setting.
- 4) FLASH KEY : Returns to the previous address number
- 5) CONF KEY : Clears data.
- 6) REDIAL KEY : Displays the data before entering program parameter.
- 7) PREV/NEXT KEY : Scrolls screens if the address has more than one screen.

Supervisor Customization

Each item can be customized by operations from the supervisor menu. The following shows the operation of customization from the supervisor menu.

Operation

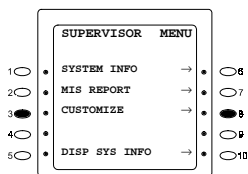

1. From [SUPERVISOR MENU] screen, press the **soft** key **3** or **8** to select [CUSTOMIZE].

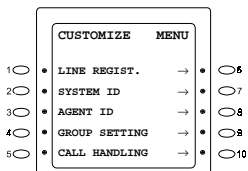

2. Select a desired menu by using the **soft** key from the [CUSTOMIZE MENU] screen.

3. For further operations, see desired section in this manual.

Direct Incoming Call Setting

Outline

COs and private lines with direct incoming ACD calls to be processed the same are grouped together as a block. Each block is assigned one of four ACD Call Handling Programs.

Set the ACD Call Handling Program number to each block, and set the ACD service call processing method.

Operation

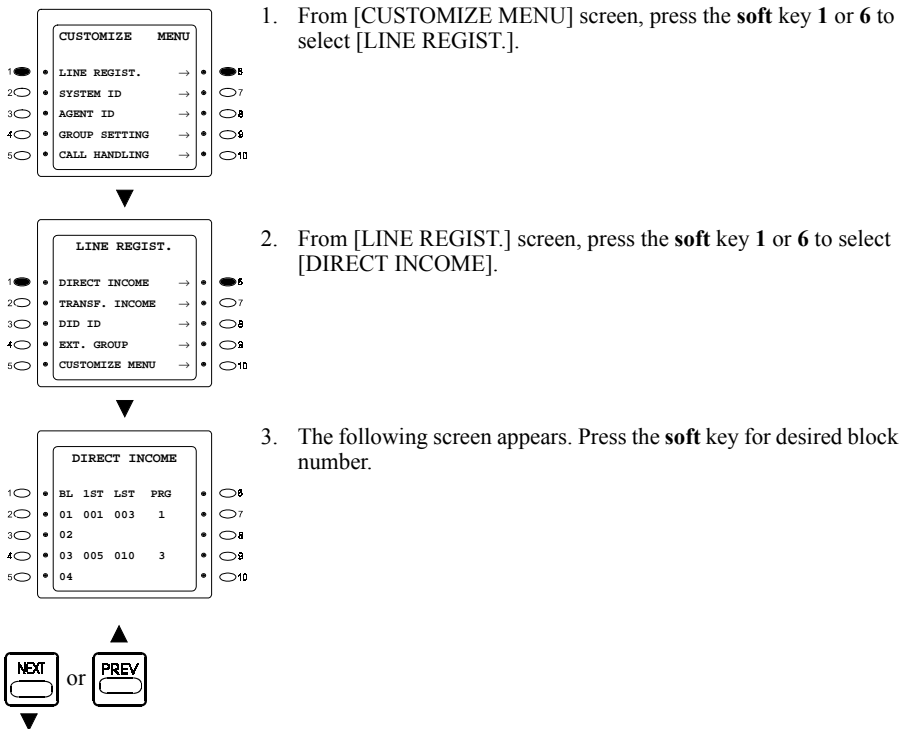

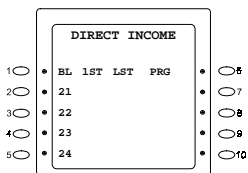

4. Enter the first CO line or private line number using the 10-key pad. (The figure on left shows setting of block No. 03.)

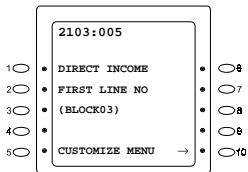

5. Press **HOLD** key to store first line number.



6. Enter the last CO line or private line number using the 10-key pad.

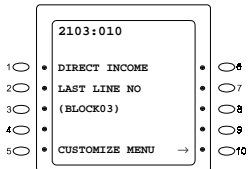

7. Press **HOLD** key to store last line number.



8. Enter the ACD Call Handling Program number.

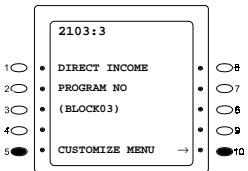

9. To return to [CUSTOMIZE MENU] screen, press the **soft** key **5** or **10**.

Transferring Incoming Call Setting

Outline

COs and private lines with transferred incoming ACD calls to be processed the same are grouped together as a block. Each block is assigned one of four ACD Call Handling Programs.

Set the ACD Call Handling Program number to each block, and set the ACD service call processing method.

Operation

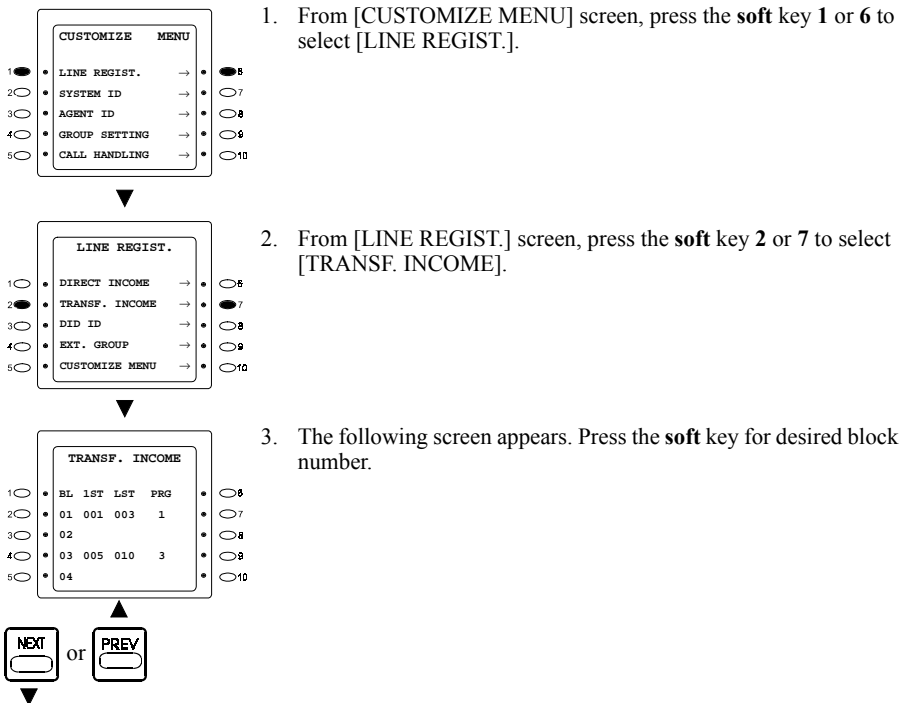

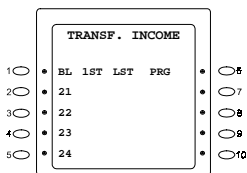

4. Enter the first CO line or private line number using the 10-key pad. (The figure on left shows setting of block No. 03.)

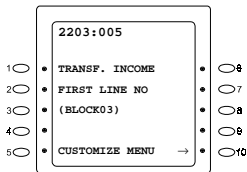

5. Press **HOLD** key to store first line number.

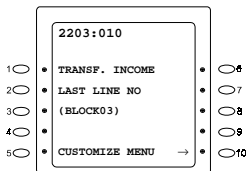

6. Enter the last CO line or private line number using the 10-key pad.



7. Press **HOLD** key to store last line number.

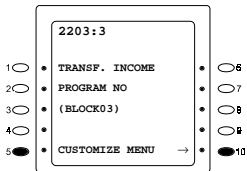

8. Enter the ACD Call Handling Program number.

9. To return to [CUSTOMIZE MENU] screen, press the **soft** key **5** or **10**.

Changing Supervisor IDs and User Information Recording ID

Outline

This procedure changes supervisor IDs and user information recording ID.

Setting

Program Address 3101:

Change the ID of Supervisor 1. The ID must be 4 digits. The initial value should be assigned by your dealer.

Program Address 3102:

Change the ID of Supervisor 2. The ID must be 4 digits. The initial value should be assigned by your dealer.

Program Address 3201:

Change the ID for user information recording. The ID must be 4 digits. The initial value should be assigned by your dealer.

Operation

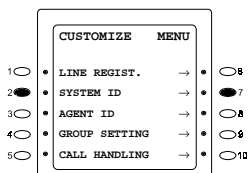

1. From [CUSTOMIZE MENU] screen, press the **soft key 2** or **7** to select [SYSTEM ID].

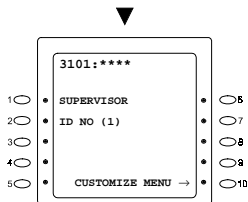

2. The 3101 setting screen appears. Enter the 4-digit ID number and press **HOLD** key to make setting. Each time the **HOLD** key is pressed, the setting changes: 3101→3102→3201.



3. Press the **soft key 5** or **10** to return to [CUSTOMIZE MENU] screen.

Notice

1. Make certain the supervisor IDs and user information recording ID are set at installation. Otherwise, you cannot enter [SUPERVISOR MENU]. Ask your dealer if they are not assigned.
2. Make sure to record the IDs because they cannot be confirmed without entering [SUPERVISOR MENU]. Ask your dealer if you forget.

Registering Agent IDs

Outline

This procedure sets agent ID numbers and their groups.

Setting

Program Address 3301~3364

Set agent ID numbers and agent groups. ID numbers are fixed to 4 digits. Set 1 or 2 as an agent group for each agent.

Operation

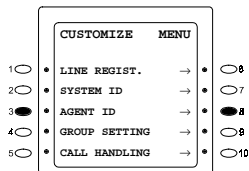

1. From [CUSTOMIZE MENU] screen, press the **soft key 3 or 8** to select [AGENT ID].

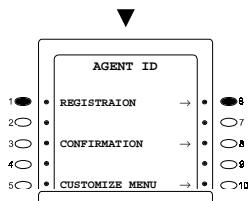

2. From [AGENT ID] screen, press the **soft key 1 or 6** to select [REGISTRATION].

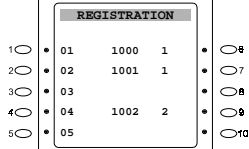

3. The following screen appears. Press the **soft key** for desired agent number.

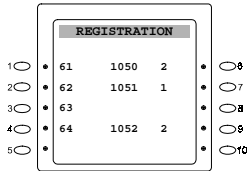
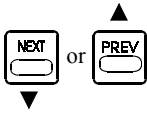

4. Enter 4-digit ID number using the 10-key pad. (The figure on left shows setting of Agent No.01.) To clear ID press **CONF** key.



5. Press **HOLD** key to store ID number.



6. Enter the agent group number (1 or 2) using the 10-key pad.

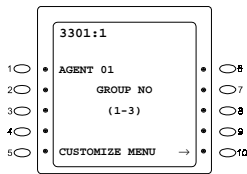

7. Press **HOLD** key to validate for this agent.



8. The next agent number is displayed. Repeat the same procedure from procedure 4 for next agent if required.

9. To return to the CUSTOMIZE MENU, press the **soft** key **5** or **10**.



Notice

1. Same agent IDs cannot be assigned. You will hear “beep beep” sound.
2. Same agent and supervisor IDs cannot be assigned. You will hear “beep beep” sound.

Confirming Agent IDs

Outline

This procedure displays the ID numbers of agents which belong to each group.

Operation

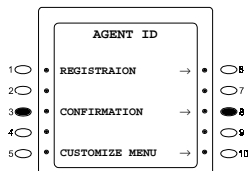

1. From [AGENT ID] screen, press the **soft key 3 or 8** to select [CONFIRMATION].

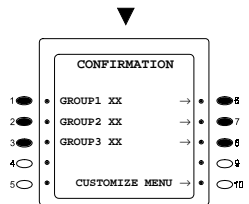

2. The screen for selecting group 1, 2 or 3 appears. The number which follows each group is the number of agents in the group. Select the agent group whose agent IDs are to be confirmed, by using **soft keys**.

Agent group 1: **soft key 1 or 6**

Agent group 2: **soft key 2 or 7**

Agent group 3: **soft key 3 or 8**

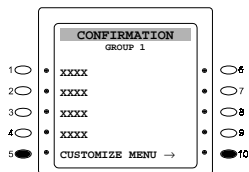

3. Registered agent ID numbers are displayed (The figure on left shows a list of agent group 1). To scroll up/down the screen, use the **PREV** or **NEXT** key.

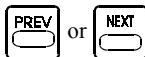

4. To return to [CUSTOMIZE MENU] screen, press the **soft key 5 or 10**.

Setting on Service Flow Details

Outline

This procedure makes a variety of settings such as service flow setting, separately for agent group 1 and agent group 2.

Operation



- From [CUSTOMIZE MENU] screen, press the **soft** key **4** or **9** select [GROUP SETTING].

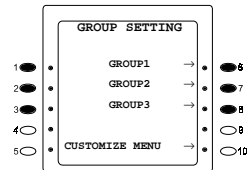

- From [GROUP SETTING] screen, use **soft** keys to select the agent group to be set.
Agent group 1: **soft** key **1** or **6**
Agent group 2: **soft** key **2** or **7**
Agent group 3: **soft** key **3** or **8**



- First setting (3401) for the selected group is displayed. Enter a set value, then press the **HOLD** key to validate setting. Every time the **HOLD** key is pressed without set values specified, the next setting item is displayed. Press **FL/R** key to return to the previous setting.



- To return to [CUSTOMIZE MENU] screen, press the **soft** key **5** or **10**.

Setting

If the first two digits of a setting number is [34], the setting pertains to group 1, [35], to group 2 and [36], to group 3. The following explanation, therefore, shows group 1/group 2/group 3 settings.

Program Address 3401/3501/3601: Agent search method

Set the agent search method. Select either of the following:

- LEAST BUSY FIRST setting. This mode first selects the agent whose busy rate (total busy time/total Login time) is the lowest in the group for the day.

- 2: NEXT AVAILABLE FIRST setting. This mode selects the agent which is placed in idle status for the longest duration following the last talking status.

Note: For both 1&2, only ACD calls will be counted as busy time or busy status.

Program Address 4101-4104: ACD Call Handling Program

Commands are used to set any call distribution operation to ACD Call Handling Program numbers (4101 to 4104).

Program Address 4201-4204: Transferring Voice Mail access number

Sets the voice mail extension line number and access code corresponding to the transfer destination voice mail number (1 to 4).

Supervisor Monitoring

The ACD system can be monitored by the supervisor. Note that data is updated every 10 seconds while the monitoring screen is displayed.

Operation

Details are given in each feature section. The following shows the operation of the supervisor monitoring from the [SUPERVISOR MENU] screen:

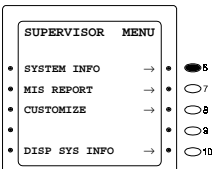
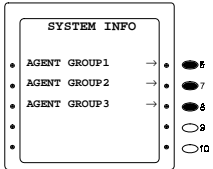
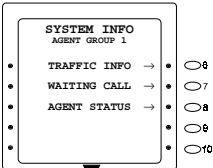
- From the [SUPERVISOR MENU] screen:
Group 1 monitoring: Press the **soft key 1 or 6** to select [SYSTEM INFO (G1)].
- 
- Group 1 monitoring: Press the **soft key 1 or 6** to select Agent Group 1.
Group 2 monitoring: Press the **soft key 2 or 7** to select Agent Group 2.
Group 3 monitoring: Press the **soft key 3 or 8** to select Agent Group 3.
- 
- After selecting one of the above groups, the following menu selection screen appears. Use **soft keys** to select a desired item. This figure shows the case where [AGENT GROUP 1] is selected.
- 

4. Select desired menu. For further operations, see next page.

Traffic Information

Operation



1. From [SYSTEM INFO] screen, press the **soft** key **1** or **6** to select [TRAFFIC INFO.].

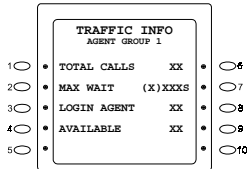

2. The following screen appears.



3. Press the **AUTO** key to return to the [SYSTEM INFO.] screen. Press the **PROG** key to return to the [SUPERVISOR MENU] screen.

Screen explanation

TOTAL CALLS : Total number of current incoming calls via the ACD system

MAX WAIT : The longest time of a current incoming call via the ACD system is placed in wait status, not connected to an agent. The unit is in seconds.

LOGIN AGENT : The number of current log in agents.

AVAILABLE : The number of agents who are available.

Waiting Call

Operation



1. From [SYSTEM INFO] screen, press the **soft** key **2** or **7** to select [WAITING CALL].

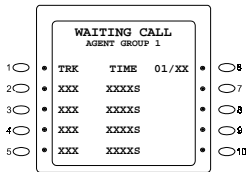

2. The following screen appears.

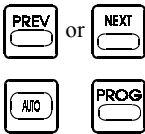

3. Press the **NEXT** key to scroll down/PREV key to scroll up the screen.
4. Press the **AUTO** key to return to the [SYSTEM INFO] screen. Press the **PROG** key to return to the [SUPERVISOR MENU] screen.

Screen explanation

TRK column: CO Line numbers for calls currently in wait status.

TIME column: Time of the call is placed in wait status.

Agent Status

Operation



1. From [SYSTEM INFO] screen, select the **soft** key **3** or **8** to select [AGENT STATUS].

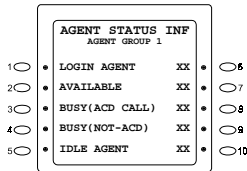

2. The following screen appears.



3. Press the **NEXT** key for additional information.

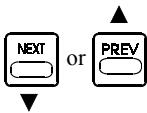
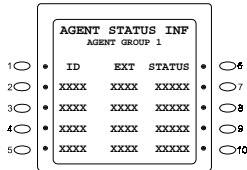

4. Press the **NEXT** key to scroll down, **PREV** key to scroll up.

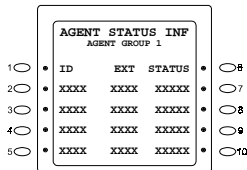

5. Press the **AUTO** KEY to return to the [SYSTEM INFO] screen. Press the **PROG** key to return to the [SUPERVISOR MENU] screen.

Screen explanation

A. First screen

LOGIN AGENT: Number of agents that have logged in.

AVAILABLE: Number of log-in agents in AVAILABLE status.

BUSY (ACD CALL): Number of agents engaged in incoming calls via the ACD system.

BUSY (NON-ACD): Number of agents engaged in calls other than the above BUSY (ACD CALL) calls.

IDLE AGENT: Number of agents ready to answer incoming calls.

B. Second and the subsequent screens

ID column: Agent IDs.

EXT column: Extension numbers used by agents.

STATUS column: Current agent status.

Meaning of the display is as follows:

Avail: The agent is in the AVAILABLE status.

Unav.: The agent is in the UNAVAILABLE status.

ACD: The agent is engaged in incoming calls via the ACD system.

N-ACD: The agent is engaged in calls other than the above ACD calls.

MIS Report Features

MIS Report Outline

The MIS Report feature provides the Supervisor with a variety of reports.

Activity of each agent, system, or a group is tabulated on an hour, day, or week (Monday to Sunday) basis. Data is saved for 14 days.

Printing order is issued from the Supervisor monitor telephone. For details, see [MIS Report Operation]. Output destination is an RS-232C-compatible printer or an RS232C-compatible personal computer (PC). To enable output to a PC, communication software is required. For details on the MIS output and connection, see the Installation Manual.

Notice

1. MIS report data memory is saved for only 14 days regardless of main cabinet's power switch status of past 14 days.
2. If the date and time of the main unit is changed, MIS report will not be accurate. In this case, output MIS report in advance, and clear the data (See Other Features/Data Clear)

3. MIS report which includes present time (for example 19:30), will be incomplete (report up to 19:00).
4. Two supervisors cannot output the MIS report simultaneously.
5. The MIS report data cannot be cleared if another supervisor has been entering the MIS REPORT MENU.
6. Two supervisors cannot enter the MIS REPORT MENU and CUSTOMIZE MENU simultaneously.
7. The definition of an ACD talk time is a time span from a call picked up to an end of a conversation or transferring to another extension.
8. If a non-Agent picks up an ACD call, MIS report will not be accurate. Therefore, the Manufacturer recommends not to assign ACD lines to FF keys.

The following gives an outline of the MIS report output.

Agent Activity

The following reports are tabulated on a per agent basis:

- Total Log-in Time, Unavailable Time, Talk Time, Idle Time & Percentage (IDLE Time=LOGIN Time-TALK Time)
- Average time from call incoming to answer.
- Number of incoming calls, number of answered calls

Group Activity

The following reports are tabulated on a per group basis:

- Total Log-in Time, Unavailable Time, Talk Time, Idle Time & Percentage (IDLE=LOGIN-TALK)
- Number of incoming calls, number of answered calls

System Activity

The following reports are tabulated on a per system basis:

- Total Log-in Time, Unavailable Time, Talk Time, Idle Time & Percentage (IDLE=LOGIN-TALK)
- Number of incoming calls, number of answered calls

Work Unit Count

The following report is tabulated:

Number of per-code calls (tabulated on a daily/weekly basis for each group/system)

MIS Function Tabulation Unit

MIS report is output in the following cycles:

- Hourly report:
Specified date(s) can be output on an hourly (0-24) basis.
- Daily report:
Data for previous week/this week can be output on a daily basis.
The oldest available data is Monday of previous week.
- Weekly report:
Data for both previous and this weeks are output on a weekly basis.

The following shows available report.

Table 6.

Group		TOTAL LOGIN TIME	UNAVAIL ABLE TIME	TALK TIME	IDLE TIME	INCOMING CALLS	ANSWER CALLS	AVERAGE RINGING TIME
Agent (1~64)	HOURLY	○	○	○	○	○	○	×
	DAILY	○	○	○	○	○	○	○
	WEEKLY	○	○	○	○	○	○	○
Group (1,or 2)	HOURLY	○	○	○	○	○	○	×
	DAILY	○	○	○	○	○	○	×
	WEEKLY	○	○	○	○	○	○	×
System	HOURLY	○	○	○	○	○	○	×
	DAILY	○	○	○	○	○	○	×
	WEEKLY	○	○	○	○	○	○	×

○ : Available to report
× : Unavailable to report

The following shows the tabulation unit of WORK UNIT COUNT.
Total count per code is shown in the following tabulation unit:

Table 7.

Unit		Code 1	Code 2	Code 3	----	Code 20
Group 1	DAILY					
	WEEKLY					
Group 2	DAILY					
	WEEKLY					
System	DAILY					
	WEEKLY					

MIS Report Operation

• Common Operation of MIS Report

MIS reports can be output by operations from the Supervisor. The following shows the MIS report output operation from [SUPERVISOR MENU]:

Operation

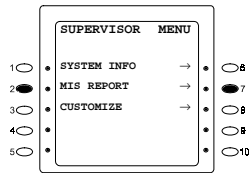

- From [SUPERVISOR MENU] screen, press the **soft** key **2** or **7** to select [MIS REPORT].
[MIS REPORT MENU] screen appears.



- Select a desired menu by using the **soft** keys from the above screen.

ACD Supervisor Mode Menu Flow Chart

Figure 4.

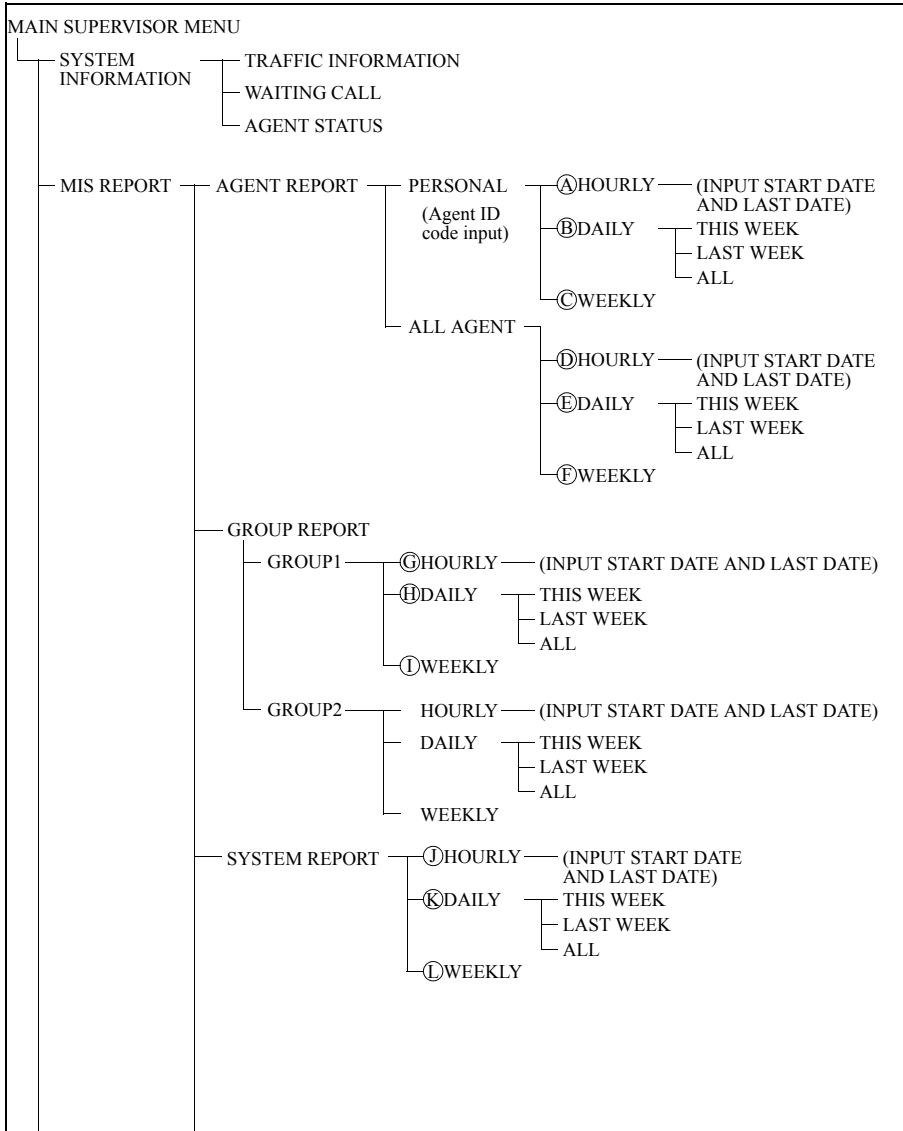

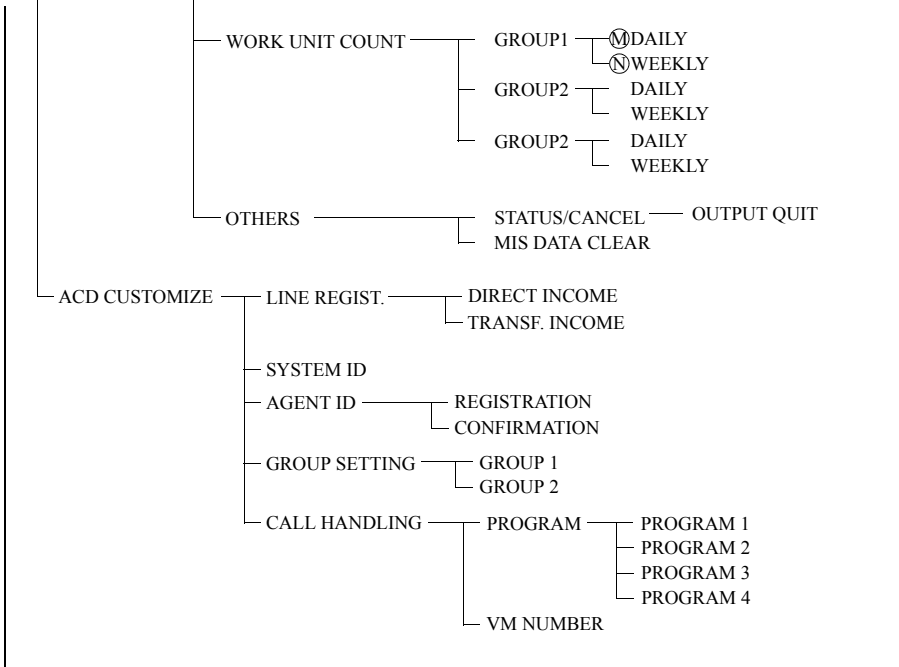

• Output of MIS Report Data

The following explains the procedure for outputting each function. The procedures below are operations from [MIS REPORT MENU] screen.

Agent Report

A. Hourly tabulation of each agent

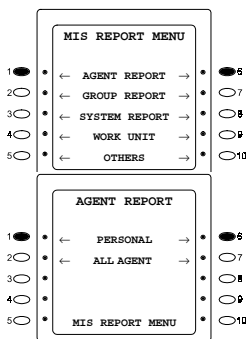

1. From [MIS REPORT] screen, press the **soft** key **1** or **6** to select [AGENT REPORT].

2. The following screen appears. Press the **soft** key **1** or **6** to select [PERSONAL].

Pressing the **soft** key **5** or **10** returns to [MIS REPORT MENU] screen (the same for the subsequent screens).

3. The following screen appears. Enter the 4-digit ID code of the target agent by using the **10**-key pad.

1	○	•	ENTER THE AGENT	•	○	6
2	○	•	ID CODE AND	•	○	7
3	○	•	PRESS HOLD KEY	•	○	8
4	○	•		•	○	9
5	○	•	MIS REPORT MENU →	•	○	10

4. The following screen appears. Press the **soft** key **1** or **6** to Select [HOURLY].

1	●	•	← HOURLY →	•	○	6
2	○	•	← DAILY →	•	○	7
3	○	•	← WEEKLY →	•	○	8
4	○	•		•	○	9
5	○	•	MIS REPORT MENU →	•	○	10

5. The following screen appears. Enter the starting date and ending date of the data to be output. First enter the starting date, press **HOLD** key to validate, then enter the ending date and press **HOLD** key again. No month is needed to be entered. For example, data for a period beginning with April 25 and ending with May 2, Enter 25 as the starting date, 2 as the ending date. For 1 through 9, 01 through 09 can be entered instead.

1	○	•	START DATE:	•	○	6
2	○	•	ENTER THE START	•	○	7
3	○	•	DATE (DD) AND PRESS	•	○	8
4	○	•	HOLD KEY	•	○	9
5	○	•	MIS REPORT MENU →	•	○	10



First date input + **HOLD** key + Last date input + **HOLD** key

1	○	•	ENTER THE LAST	•	○	6
2	○	•	DATE (DD) AND PRESS	•	○	7
3	○	•	HOLD KEY	•	○	8
4	○	•		•	○	9
5	○	•	MIS REPORT MENU →	•	○	10



6. Once the input data is validated, the data output starts. The following screen appears while the output is in progress. To abort output, see the section [MIS data output abort] section of, [Other Features].

1	○	•	MIS OUTPUT	•	○	6
2	○	•	AGENT ID:XXXX	•	○	7
3	○	•	HOURLY REPORT	•	○	8
4	○	•	FROM XX TO XX	•	○	9
5	○	•	MIS REPORT MENU →	•	○	10

B. Daily tabulation of each agent

Steps 1 to 3 are the same as those for item A.

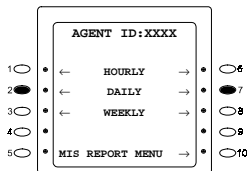

- The following screen appears. Press the **soft** key **2** or **7** to Select [DAILY].



- The following screen appears. Press the **soft** key **1** or **6** for [THIS WEEK], **2** or **7** for [LAST WEEK], **3** or **8** for [ALL].



- Once the input data is validated, the data output starts. The following screen appears while the output is in progress. To abort output, see the [MIS data output abort] section, [Other Features]. (The figure on left shows outputting of this week)

C. Weekly tabulation of each agent

Steps 1 to 3 are the same as those for item A.

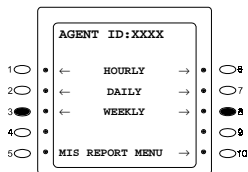

- The following screen appears. Press the **soft** key **3** or **8** to select [WEEKLY].

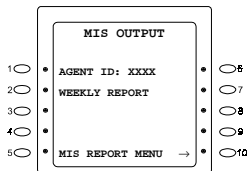

- Once the input data is validated, the data output starts. The following screen appears while the output is in progress. To abort output, see the section [MIS data output abort], section, [Other Features]

D. Hourly tabulation of all agents

E. Daily tabulation of all agents

F. Weekly tabulation of all agents

Step 1 is the same as that for items A.



- From the following screen, press the **soft key 2 or 7** to select [ALL AGENT].

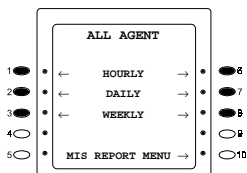

- The following screen appears. Press the **soft key 1 or 6** to select [HOURLY], **2 or 7** to select [DAILY], **3 or 8** to select [WEEKLY].

- Follow steps 5 and 6 of item A for [HOURLY].
 Follow steps 5 and 6 of item B for [DAILY].
 Follow steps 5 of item C for [WEEKLY].

Group Report

G. Hourly tabulation of group report

H. Daily tabulation of group report

I. Weekly tabulation of group report



- From [MIS REPORT] screen, press the **soft key 2 or 7** to select [GROUP REPORT].

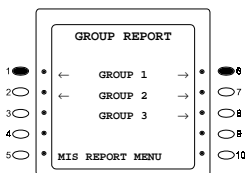

- The following screen appears. Press the **soft key 1 or 6**, **2 or 7** or **3 or 8** to select [GROUP1/GROUP2/GROUP3]. Pressing the **soft key 5 or 10** returns to [MIS REPORT MENU] screen (the same for the subsequent screens).
 The following procedure assumes that [GROUP 1] is selected:

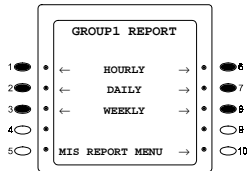

3. The following screen appears. Press the **soft** key **1** or **6** to select [HOURLY], **2** or **7** to select [DAILY], **3** or **8** to select [WEEKLY].

4. Follow steps 5 and 6 of item A for [HOURLY].
Follow steps 5 and 6 of item B for [DAILY].
Follow steps 5 of item C for [WEEKLY].

System Report

J. Hourly tabulation of system report

K. Daily tabulation of system report

L. Weekly tabulation of system report



1. From [MIS REPORT] screen, press the **soft** key **3** or **8** to select [SYSTEM REPORT].

2. The following screen appears. Press the **soft** key **1** or **6** to select [HOURLY], **2** or **7** to select [DAILY], **3** or **8** to select [WEEKLY].

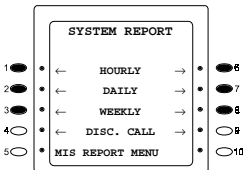

3. Follow steps 5 and 6 of item A for [HOURLY].
Follow steps 5 and 6 of item B for [DAILY].
Follow steps 5 of item C for [WEEKLY].

Work Unit Count

M. Daily tabulation of work unit count



1. From [MIS REPORT] screen, press the **soft** key **4** or **9** to select [WORK UNIT].

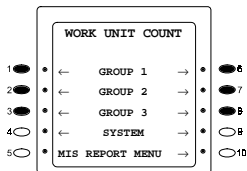

- The following screen appears. Press the **soft key 1, 2 or 3, or 5, 6 or 7** to select [GROUP1/GROUP2/SYSTEM]. GROUP1 represents Agent Group 1 and GROUP2 represents Agent Group 2. SYSTEM represents the total sum of Group 1 and Group 2. The following procedure assumes that Group 1 is selected (the operation is the same if another option is selected).

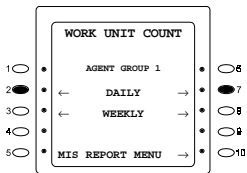

- The following screen appears. Press the **soft key 2 or 7** to select [DAILY].

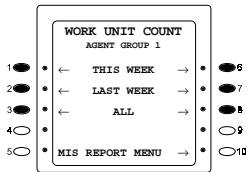

- From the following screen, press the **soft key 1, 2, 3 or 6, 7, 8** to select [THIS WEEK], [LAST WEEK], [ALL]. When [THIS WEEK] is selected, data is output from Monday of this week. When [LAST WEEK] is selected, data is output from Monday to Sunday of last week. When [ALL] is selected, all data from Monday of last week will be output.

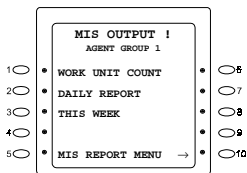

- Once the input data is validated, the data output starts. The following screen appears while the output is in progress. To abort output, see the section [MIS data output abort] section, [Other Features].

N. Weekly tabulation of work unit count

Steps 1 to 2 are the same as those for item M.

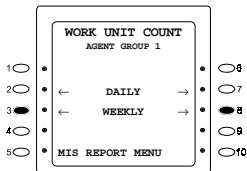

- The following screen appears. Press the **soft key 3 or 8** to select [WEEKLY].



- Once the input data is validated, the data output starts. The following screen appears while the output is in progress. To abort output, see the section [MIS data output abort] of [Other Features].

Other Features (Data Clear and Output Cancel)

O. MIS data clear

* This feature clears all MIS data.



- From [MIS REPORT] screen, press the **soft** key **5** or **10** to select [OTHERS].

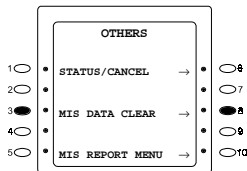

- The following screen appears. Press the **soft** key **3** or **8** to select [MIS DATA CLEAR].

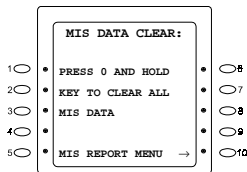

- The following screen appears. To clear data, press **0** and **HOLD** keys. This starts data clear processing.

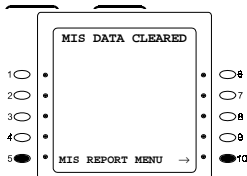

- Once data clear is completed, the following screen appears. Pressing the **soft** key **5** or **10** returns to [MIS REPORT MENU] screen.

P. MIS data output confirmation/cancel

* This feature confirms/cancels MIS data output.

- Step 1 is the same as that for item O.
- The following screen appears. Press the **soft** key **1** or **6** to select [STATUS/CANCEL].

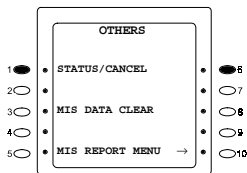

- The following screen appears to show the current MIS data output status on the Large Display (end of confirmation). To abort MIS data output, press the **soft** key **4** or **9** to select [QUIT]. The following screen assumes that daily report of Agent ID XXXX is being output.

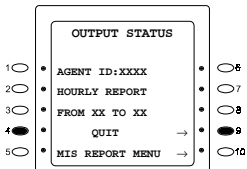

- The following screen appears. To quit, press **0** and **HOLD** keys.

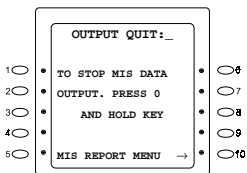

- Once output is cancelled, the following screen appears. Pressing the **soft** key **5** or **10** returns to [MIS REPORT MENU] screen.



User Information Recording

The following (Figure 5) shows the service flow for recording user information messages. Voice output ports of the ACD system can be directly accessed to register, confirm, change, or delete messages. The maximum recording length of each service information message is 14 seconds. Up to 6 kinds of information messages can be registered per ACD system.

After recording your information message(s), select which information message to be sent to an outside party by entering parameter on service Flow Details (Figure 2).

Related program addresses are:

- 4101 - 4104: ACD Call Handling Program
- 4201 - 4204: Transferring Voice Mail access number

Notice

Even if your message are recorded, using Figure 5, user information numbers (1-6) must be selected for above program addresses. If they are not selected, initial messages will be sent.

Figure 5.

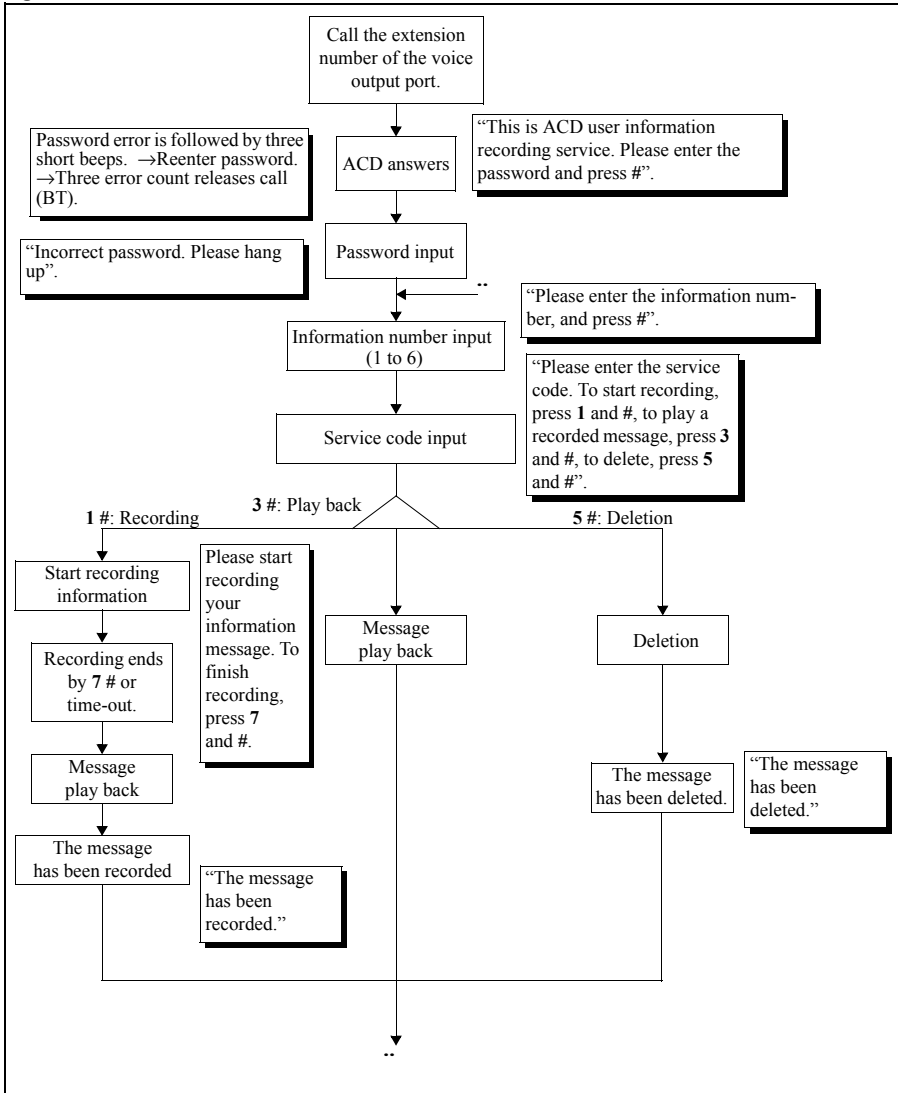

Agent Features

Log-in / Log-out

Log-in procedure



1. Press the **LOGIN** key then, press the AGENT ID CODE.
2. The LED lights in green to notify completion of log-in.
3. Press **ON/OFF** key after the completion of log-in.



Notice

1. **LOGIN** key must be assigned in advance (See key Assignment).
2. Entering an unregistered agent ID code displays an error. In this case, do the procedure from the beginning again after pressing ON/OFF key.
3. Do not Log-in or Log-out while placing a call on hold.

If the extension is already logged in, another agent cannot log in using his/her agent ID. The Current agent must log out once to log in again.

Log-out procedure



1. Press the **LOGIN** key while the key LED is illuminated in green.
2. The key LED goes off to notify the completion of log-out.
3. Press **ON/OFF** key.



Available/Unavailable

Pressing the **UNAVAILABLE** key from an idle terminal which is logged in places the extension in the Unavailable status temporarily. This **UNAVAILABLE** excludes the telephone from candidates of ACD incoming calls. Pressing the key again returns the telephone into the Available status. This key's LED illuminates in green for the Available status and red for the Unavailable status. Same as the **LOGIN** key, the **UNAVAILABLE** key LED goes off with log-out procedure.

Operation



To activate **UNAVAILABLE** status:
Press the green/**UNAVAILABLE** key (the key LED illuminates in red).



To return to **AVAILABLE** status:
Press the red/**UNAVAILABLE** key (the key LED illuminates in green).

Notice

1. **UNAVAILABLE** key must be assigned in advance (See key Assignment).
2. If an agent does not answer an ACD incoming call before a specific time (Initial: 10 sec.), the agent will become **UNAVAILABLE** automatically.

Log Out Confirmation Feature

When you are logged in as an Agent, you can use this feature to check the number of callers in the queue and to see the longest call waiting time.

Operation

After logging in:



1. Press the **LOGIN** key once. Your telephone displays:

Log Out?
Que XX Long YYY

XX= Number of calls in queue (Max 99)
YYY= Longest call waiting time in minutes (Max 999)



2. Do one of the following:
 - To remain logged in, press the **ON/OFF** key.



- To log out, press the **LOGIN** key.

Notice

3. Before you can use the Log Out Confirmation feature, the feature must be enabled as described in the Log Out Confirmation programming instructions in *Section 520: Built-In ACD Reference* manual for the DBS 576..

Work Unit Count

Work Unit Codes can be preset with the Work Unit Count key. When used, they appear in the MIS report. For example, 01 for claims, 02 for sales, 03 for brochure. A maximum of 20 codes can be entered (set at installation).

Operation



1. Press Work Unit key while ACD call.
This lights the LED in red. Pressing the key again turns off the LED and deletes code. The number of codes per call is not restricted (multiple count is allowed).

Notice

1. The Work Unit Count key is effective only from an agent telephone and while the telephone is engaged in an ACD call.
2. When the call is placed on hold, the LED remains on. It goes off if another telephone retrieves the call placed on hold. If the same telephone retrieves the call placed on hold the LED remains on, and goes off when the call is released.

Zip Tone

Zip mode automatically answers calls when an agent is using the Headset mode. With the Zip mode enabled, the agent hears a brief alert tone via the headset before the system automatically answers the incoming call.

Operation

The user hears the notification (ZIP) tone and the call is automatically connected.

Setting

When in Headset mode:

1. Press the **ON/OFF** key.
2. Press the **PROG** key.
3. Dial **80** to toggle ZIP Mode ON and OFF.
4. The telephone LCD panel displays **ZIP MODE ON** or **ZIP MODE OFF**.

Notes:

1. Call Forwarding takes precedence over the Zip mode.

Key Assignment

Assign the following keys to the Flexible Function (FF) keys of each telephone (setting at installation work). You must not assign more or less than one LOGIN or AVAILABLE key to one telephone:

- LOGIN (mandatory)
- UNAVAILABLE (mandatory)
- WORK UNIT COUNT (01-20: optional)

Setting

1. Press the **ON/OFF** key and **PROG** key.

2. Select a vacant **FF** key.
3. Press **REDIAL** key.
4. Select to feature code to assign.

Feature Description	Fixed Feature Code + (additional digits to program into key)
ACD-1 Log-In/Out Key	*#80
ACD-1 Work Unit Key	*#81 + (Work Unit 01-20)
ACD-1 Unavailable Key	*#82
ACD-2 Log-In/Out Key	*#85
ACD-2 Work Unit Key	*#86 + (Work Unit 01-20)
ACD-2 Unavailable Key	*#87
ACD Silent Monitor Key (two touch)	77 + desired extension (DBS 576 only)
ACD Silent Monitor Key (one touch)	77 (DBS 576 only)
Zip Tone Mode ON/OFF Key	*73

5. Press **HOLD** key to store.
6. Press **ON/OFF** key to end.

Notice

1. If an **FF** key selected in setting 2 is not vacant (Pre-assigned), the previous setting will be erased automatically.
2. To confirm an **FF** key assignment, press **ON/OFF-CONF-FF** key.
3. To delete an **FF** key assignment, skip procedures 3 & 4 of setting procedure.

Index

A	
ACD Call Handling Program	5
Activating Supervisor Menu	16
Agent Features	47
Agent IDs	
Confirming	26
Registering	24
Agent Report	37
Agent Status	31
ALL DELETE (FF6).....	12
Available/Unavailable.....	48

B	
Basic Service Flow.....	4

C	
Call Handling Program	5
Call Setting	
Direct Incoming.....	19
Transferring Incoming.....	21
Changing Supervisor IDs and User Information Record- ing ID	23
Commands	
Programming	7
Common Operation for Supervisor Customization	17
Configuration	1
Confirming Agent IDs	26
Customization	
Supervisor.....	18

D	
Data Clear	43
DELETE (FF3)	11
Direct Incoming Call Setting	19

E	
EDIT (FF1)	8

F	
Features	
Supervisor	16

G	
Group Report	40

I	
Information Recording	
User	45

INSERT (FF2).....10

K

Key Assignment.....50

L

Log Out Confirmation.....48

Log-in / Log-out.....47

M

MIS Report Data
Output.....37

MIS Report Features.....32

MIS Report Operation.....35

MIS Report Outline.....32

Monitoring.....28

O

Other Features (Data Clear and Output Cancel).....43

Output Cancel.....43

Output of MIS Report Data.....37

P

Programming by Commands.....7

R

RAD.....8

Recording
User Information.....45

Registering Agent IDs.....24

Report Operation
MIS.....35

Report Outline
MIS.....32

S

Service Flow.....4

Service Flow Details
Setting.....27

Setting on Service Flow Details.....27

Silent Monitor.....14

Specifications.....2

Supervisor Customization.....18

Supervisor Features.....16

Supervisor ID
Changing.....23

Supervisor Menu
Activating.....16

Supervisor Monitoring.....28

System Report.....41

T

Traffic Information.....29

Transfer Destination Voice Number.....13

Transferring Incoming Call Setting.....21

U

Unavailable.....48

User Information Recording.....45

User Information Recording ID
Changing.....23

W

Waiting Call.....30

Work Unit Count.....41, 49

Z

Zip Tone.....50

Panasonic

Telecommunication Systems Company

Division of Matsushita Electric Corporation of America

Business Telephone Systems Division

Headquarters

Two Panasonic Way

Secaucus, NJ 07094

(201) 392-4220